

OPERATING INSTRUCTIONS

**RF DIRECTIONAL
THRULINE
POWER SENSORS**

MODEL 4020 SERIES

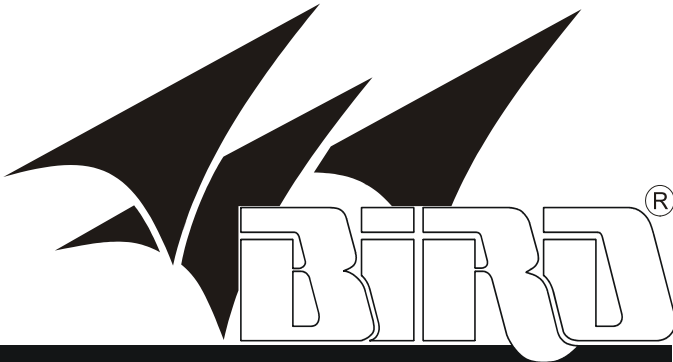

TECHNOLOGIES GROUP

BIRD ELECTRONIC

TX RX SYSTEMS

Specifications

CAUTION

Changing the sensor's connectors will invalidate calibration data, and may reduce the maximum power rating of the unit.

| | |
|---|---|
| Frequency Range | |
| 4021 | 1.8 – 32 MHz |
| 4022 | 25 MHz – 1 GHz |
| 4024 | 1.5 – 32 MHz |
| 4025 | 100 kHz – 2.5 MHz |
| RF Power Range | |
| 4021, 4022 | 300 mW – 1 kW |
| 4024, 4025 | 3 W – 10 kW |
| Accuracy, Fwd, Best Case* | ± 3% (1σ) |
| Accuracy, Reflected | Calculated from Fwd accuracy and power $\text{RFL Accuracy} = \text{FWD Accuracy} + \frac{\text{FWD Power}}{10^{\text{Directivity}/10}}$ |
| Accuracy, VSWR | Calculated from FWD and RFL power $\text{VSWR} = \left(1 + \sqrt{\frac{P_R}{P_F}} \right) / \left(1 - \sqrt{\frac{P_R}{P_F}} \right)$ |
| Impedance, Nominal | 50 ohms |
| VSWR, Max. | |
| 4021, 4024, 4025 | 1.05:1 |
| 4022 | 1.05:1, 25 – 512 MHz 1.10:1, 512 MHz – 1 GHz |
| Insertion Loss, Max. (with female “N” connectors) | |
| 4021, 4024, 4025 | 0.05 dB |
| 4022 | 0.05 dB, 25 – 512 MHz 0.13 dB, 512 MHz – 1 GHz |
| Directivity, Min. | |
| 4021, 4022 | 30 dB |
| 4024 | 28 dB, 1.5 – 2.5 and 25 – 32 MHz 30 dB, 2.5 – 25 MHz |
| 4025 | 28 dB, 100 – 125 kHz 30 dB, 125 – 2500 kHz |

| | |
|---------------------------------|--|
| Max. Allowable Terminating VSWR | 2.00:1 |
| VSWR Range | 1.00 to 2.00 (40.0 to 9.5 dB Return Loss) |
| Calibration Technique | Frequency-specific calibration factors stored in nonvolatile memory in each sensor. Sensor output corrected for frequency and temperature within specified ranges. |
| Cal. Cycle, Nominal | 1 year |
| Connectors | Customer specified from QC list, appropriate for frequency and power. |
| Sampling Rate, Nominal | 2 readings/second |
| Operating Power | Supplied by power meter via sensor cable |
| Humidity, Max. | 95% (Non-condensing) |
| Altitude, Max. | 10,000 feet (3,000 m) |
| CE | CE Compliant. Refer to Declaration of Conformity for specific standards. |
| Temperature Range | |
| Operating | 0 to 50 °C (32 to 122 °F) |
| Storage | -20 to +70 °C (-4 to +158 °F) |
| Dimensions | 5.2" L x 2.5" W x 3.25" H (137 x 64 x 83 mm) |
| Weight, Nominal | 1 lb. 13 oz. (0.8 kg) |

* For rated accuracy, no more than 1% AM; Harmonics -50 dBc or less
Derate accuracy by 3.0% (1σ) below 15 °C and above 35 °C

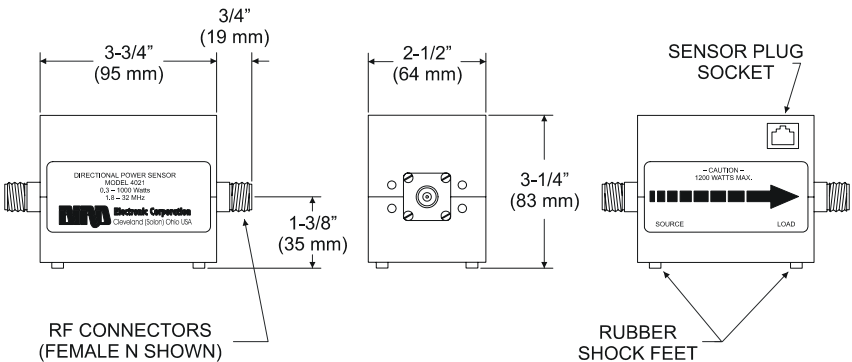

Special Lifetime Warranty – Series 4020 Power Sensor Head

In addition to its standard warranty, the Bird Electronic Corporation warrants its Series 4020 Thruline® Power Sensor Heads for lifetime to original purchaser. This extended warranty is against burnout. For the warranty to apply, the Sensor Head must be used with the correct Bird Electronic Corporation Display Unit, the maximum power rating of the Sensor must not be exceeded, the Sensor RF circuit must be properly terminated and the Sensor not subjected to physical abuse.

Bird Electronic Corporation, at its option, will repair or replace the defective Sensor at its world Headquarters at 30303 Aurora Road, Solon, Ohio 44139.

The customer is responsible to pay transportation charges to return the defective sensor to Bird.