

---

INSTRUCTION BOOK

# Directional Power Sensor

**5010B & 5014**



---

©*Copyright* 2009 by Bird Electronic Corporation  
Instruction Book Part Number 920-5010S Rev. B

## Safety Precautions

---

The following are general safety precautions that are not necessarily related to any specific part or procedure, and do not necessarily appear elsewhere in this publication. These precautions must be thoroughly understood and apply to all phases of operation and maintenance.

### WARNING

#### **Keep Away From Live Circuits**

Operating Personnel must at all times observe general safety precautions. Do not replace components or make adjustments to the inside of the test equipment with the high voltage supply turned on. To avoid casualties, always remove power.

### WARNING

#### **Shock Hazard**

Do not attempt to remove the RF transmission line while RF power is present.

### WARNING

#### **Do Not Service Or Adjust Alone**

Under no circumstances should any person reach into an enclosure for the purpose of service or adjustment of equipment except in the presence of someone who is capable of rendering aid.

**WARNING**

**Safety Earth Ground**

An uninterruptible earth safety ground must be supplied from the main power source to test instruments. Grounding one conductor of a two conductor power cable is not sufficient protection. Serious injury or death can occur if this grounding is not properly supplied.

**WARNING**

**Resuscitation**

Personnel working with or near high voltages should be familiar with modern methods of resuscitation.

## **Safety Symbols**

**WARNING**

Warning notes call attention to a procedure, which if not correctly performed, could result in personal injury.

**CAUTION**

Caution notes call attention to a procedure, which if not correctly performed, could result in damage to the instrument.

 **Note:** *Calls attention to supplemental information.*

## Warning Statements

The following safety warnings appear in the text where there is danger to operating and maintenance personnel, and are repeated here for emphasis.

### WARNING

Leaking RF energy is a potential health hazard. DO NOT connect or disconnect equipment from the transmission line while RF power is being applied. Severe burns, electrical shock, or death can occur..

On page 2.

### WARNING

Never attempt to connect or disconnect RF equipment from the transmission line while RF power is being applied. Leaking RF energy is a potential health hazard

On page 5.

### WARNING

RF voltage may be present in RF element socket. Keep element in socket during operation.

On page 5.

## Caution Statements

The following equipment cautions appear in the text and are repeated here for emphasis.

### CAUTION

If the element cannot be fully inserted into the socket, do not force it. This may damage the element.

On page 2.

## **Safety Statements**

### **USAGE**

ANY USE OF THIS INSTRUMENT IN A MANNER NOT SPECIFIED BY THE MANUFACTURER MAY IMPAIR THE INSTRUMENT'S SAFETY PROTECTION.

### **USO**

EL USO DE ESTE INSTRUMENTO DE MANERA NO ESPECIFICADA POR EL FABRICANTE, PUEDE ANULAR LA PROTECCIÓN DE SEGURIDAD DEL INSTRUMENTO.

### **BENUTZUNG**

WIRD DAS GERÄT AUF ANDERE WEISE VERWENDET ALS VOM HERSTELLER BESCHRIEBEN, KANN DIE GERÄTESICHERHEIT BEEINTRÄCHTIGT WERDEN.

### **UTILISATION**

TOUTE UTILISATION DE CET INSTRUMENT QUI N'EST PAS EXPLICITEMENT PRÉVUE PAR LE FABRICANT PEUT ENDOMMAGER LE DISPOSITIF DE PROTECTION DE L'INSTRUMENT.

### **IMPIEGO**

QUALORA QUESTO STRUMENTO VENISSE UTILIZZATO IN MODO DIVERSO DA COME SPECIFICATO DAL PRODUTTORE LA PROZIONE DI SICUREZZA POTREBBE VENIRNE COMPROMESSA.

## **SERVICE**

SERVICING INSTRUCTIONS ARE FOR USE BY SERVICE - TRAINED PERSONNEL ONLY. TO AVOID DANGEROUS ELECTRIC SHOCK, DO NOT PERFORM ANY SERVICING UNLESS QUALIFIED TO DO SO.

## **SERVICIO**

LAS INSTRUCCIONES DE SERVICIO SON PARA USO EXCLUSIVO DEL PERSONAL DE SERVICIO CAPACITADO. PARA EVITAR EL PELIGRO DE DESCARGAS ELÉCTRICAS, NO REALICE NINGÚN SERVICIO A MENOS QUE ESTÉ CAPACITADO PARA HACERLO.

## **WARTUNG**

ANWEISUNGEN FÜR DIE WARTUNG DES GERÄTES GELTEN NUR FÜR GESCHULTES FACHPERSONAL. ZUR VERMEIDUNG GEFÄHRLICHE, ELEKTRISCHE SCHOCKS, SIND WARTUNGSARBEITEN AUSSCHLIEßLICH VON QUALIFIZIERTEM SERVICEPERSONAL DURCHZUFÜHREN.

## **ENTRETIEN**

L'EMPLOI DES INSTRUCTIONS D'ENTRETIEN DOIT ÊTRE RÉSERVÉ AU PERSONNEL FORMÉ AUX OPÉRATIONS D'ENTRETIEN. POUR PRÉVENIR UN CHOC ÉLECTRIQUE DANGEREUX, NE PAS EFFECTUER D'ENTRETIEN SI L'ON N'A PAS ÉTÉ QUALIFIÉ POUR CE FAIRE.

## **ASSISTENZA TECNICA**

LE ISTRUZIONI RELATIVE ALL'ASSISTENZA SONO PREVISTE ESCLUSIVAMENTE PER IL PERSONALE OPPORTUNAMENTE ADDESTRATO. PER EVITARE PERICOLOSE SCOSSE ELETTRICHE NON EFFETTUARRE ALCUNA RIPARAZIONE A MENO CHE QUALIFICATI A FARLA.

**RF VOLTAGE MAY BE PRESENT IN RF ELEMENT  
SOCKET - KEEP ELEMENT IN SOCKET DURING  
OPERATION.**

**DE LA TENSION H.F. PEAT ÊTRE PRÉSENTE DANS  
LA PRISE DE L'ÉLÉMENT H.F. - CONSERVER  
L'ÉLÉMENT DANS LA PRISE LORS DE L'EMPLOI.**

**HF-SPANNUNG KANN IN DER HF-ELEMENT-  
BUCHSE ANSTEHEN - ELEMENT WÄHREND DES  
BETRIEBS EINGESTÖPSELT LASSEN.**

**PUEDE HABER VOLTAJE RF EN EL ENCHUFE DEL  
ELEMENTO RF - MANTENGA EL ELEMENTO EN EL  
ENCHUFE DURANTE LA OPERACION.**

**IL PORTAELEMENTO RF PUÒ PRESENTARE  
VOLTAGGIO RF - TENERE L'ELEMENTO NELLA  
PRESA DURANTE IL FUNZIONAMENTO.**

## About This Manual

---

This manual covers the operating and maintenance instructions for the following models:

5010B

5014

### Changes to this Manual

We have made every effort to ensure this manual is accurate. If you discover any errors, or if you have suggestions for improving this manual, please send your comments to our Solon, Ohio factory. This manual may be periodically updated. When inquiring about updates to this manual refer to the part number and revision on the title page.

### Literature Contents

#### Chapter Layout

**Introduction** — Describes the features of the Directional Power Sensor and Element Types.

**Installation** — Describes how to connection and install the Directional Power Sensor into the system that is being monitored.

**Specifications** - Describes the basic information, settings, and ranges of the Digital Power Sensor.



# Table of Contents

---

|   |            |
|---|------------|
| <b>Safety Precautions</b> .....                       | <b>0</b>   |
| Safety Symbols.....                                   | i          |
| Warning Statements.....                               | ii         |
| Caution Statements.....                               | ii         |
| Safety Statements.....                                | iii        |
| <b>About This Manual</b> .....                        | <b>vii</b> |
| Changes to this Manual.....                           | vii        |
| Literature Contents.....                              | vii        |
| Chapter Layout.....                                   | vii        |
| <b>Chapter 1 Introduction</b> .....                   | <b>1</b>   |
| Description.....                                      | 1          |
| Element Types.....                                    | 1          |
| 43 Type Elements.....                                 | 1          |
| APM/DPM Elements.....                                 | 2          |
| Element Orientation.....                              | 2          |
| Element Contact Alignment.....                        | 3          |
| <b>Chapter 2 Installation</b> .....                   | <b>5</b>   |
| Connecting the Directional<br>Power Sensor (DPS)..... | 5          |
| <b>Chapter 3 Specifications</b> .....                 | <b>7</b>   |
| 5010B Specifications.....                             | 7          |
| 5014 Specifications.....                              | 11         |
| <b>Limited Warranty</b> .....                         | <b>15</b>  |



## Description

The DPS series sensors utilize elements in order to make power measurements. Each element has an arrow on it that represents the direction in which it measures power. The elements ignore power in the opposite direction with a directivity of at least 25 dB. The DPS series can make power measurements using either 43 type or APM/DPM elements, and the readings available vary, based on which elements are being used.

Since the DPS uses two elements, it can measure the quality of the system by comparing the forward and the reflected power. This is usually presented in the form of VSWR (voltage standing wave ratio) or Return Loss.

## Element Types

### 43 Type Elements

The 43 type elements are normally used to measure peak power. These elements can measure the peak power of a system with an accuracy of +/-8% of full scale as long as the signal meets the following requirements:

- At least 15 pps (pulses per second)
- Minimum pulse width of 15  $\mu$ s (800 ns if frequency is greater than 100 MHz)
- Minimum Duty Cycle of 0.01%

In addition, 43 type elements can be used to measure average power in signals with a peak-to-average ratio close to 1, like a CW or FM signals. In these cases, the average power is measured with an accuracy of +/- 5% of full scale.

### **APM/DPM Elements**

The APM/DPM elements are used to measure true average power. True average power means the sensor provides equivalent heating power of the signal, regardless of modulation or number of carriers. These elements can measure average power with an accuracy of +/-5% of reading from full scale down to 2.5% of full scale.

 **Note:** *The equivalent heating power is dependent on the duty cycle of a signal. If a system puts out 50 watts with a 50% duty cycle, the APM/DPM elements will measure 25 watts.*

### **Element Orientation**

#### **WARNING**

Leaking RF energy is a potential health hazard. DO NOT connect or disconnect equipment from the transmission line while RF power is being applied. Severe burns, electrical shock, or death can occur.

The forward element and the reflected element must be of the same series (APM or 43). The power rating of the forward element must be 10x the power rating of the reverse element.

Insert the forward element into the forward socket with its arrow pointing in the direction of forward power. Insert the reflected element into the reflected socket with its arrow pointing in the direction of reverse power.

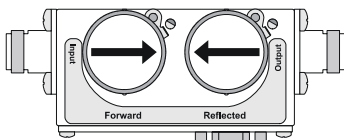

## Element Contact Alignment

Continuous insertion or rotation of the element might cause a slight change in the position of the contact spring in the element socket. If the contact spring changes position, erratic power readings may be experienced.

The position of the contact spring may be adjusted with a small screwdriver to reestablish contact.

### CAUTION

If the element cannot be fully inserted into the socket, do not force it. This may damage the element.

Perform the following steps to adjust the contact spring:

1. Using a small flat head screwdriver, place the flat side of the screwdriver behind the contact bar as indicated and bend the contact bar so that the contact rests in the center of the slot adjacent to the element socket.

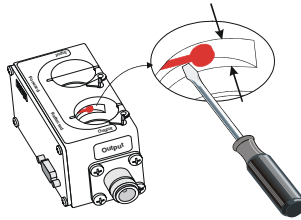

2. After centering the contact, bend the contact bar slightly toward the center of the element socket bore, so that the profile of the element contact is visible when viewing the element socket from the top of the socket bore.

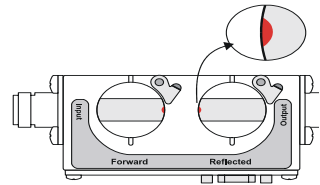
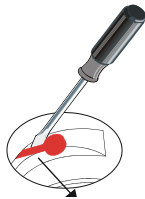

**Note:** *If the contact is accidentally moved too far, the element will not slide into the socket. Move the contact back into the recessed area and repeat the process.*

### WARNING

Never attempt to connect or disconnect RF equipment from the transmission line while RF power is being applied.  
Leaking RF energy is a potential health hazard.

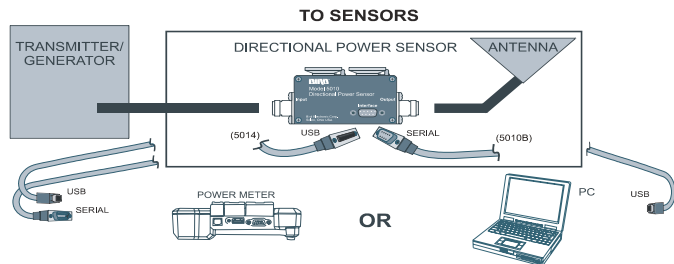



### Connecting the Directional Power Sensor (DPS)

#### WARNING

RF voltage may be present in RF element socket.  
Keep element in socket during operation.

1. Do one of the following:
  - To connect to a Digital Power Meter:
  - For Models 5010 and 5010B:  
Connect the Bird DPS to the “Sensor” serial port on the DPM using the sensor cable provided.

- For Models 5014:  
Connect the Bird DPS to the “Sensor” USB port on the DPM using the sensor cable provided.
  - To connect to a PC with VPM2 software (5014 ONLY):
    - Connect the Bird DPS to the a USB port on the PC using the sensor cable provided.
2. Connect the DPS to the RF line so that the arrow on the sensor points towards the load, see “Element Orientation” on page 2.
    -  **Note:** *The arrow on the forward element should point towards the load.*
    -  **Note:** *The arrow on the reflected element should point towards the source.*
    -  **Note:** *Both elements must be either APM/ DPM or 43 types, do not mix elements.*
  3. Set the power on the DPM to the forward element’s power rating.

## 5010B Specifications

|  |  |
|--|--|
| <b>Sensor Type</b>   | ThruLine two-element line section  |
| <b>Elements</b><br><br>5010B<br>5010T  | Select two elements from the same series, with RFL power 1/10 of FWD power.<br><br>APM or 43 series elements<br>APM elements <i>only</i> |
| <b>Frequency Range<sup>a</sup></b>   | 2 – 3600 MHz   |
| <b>Average Power Measurement, APM Elements, Forward or Reflected Direction</b> |  |
| <b>Power Measurement Range<sup>a</sup></b>                                     | 0.1 W to 1 kW  |
| <b>Uncertainty<sup>b</sup></b>   | ± 5% of reading (95% c.l.)   |
| <b>Peak/Average Ratio, Max</b>   | 10 dB  |
| <b>Detector Response (5010T only)</b>  | 230 ms   |
| <b>Average Power Measurement, APM Elements, Forward or Reflected Direction</b> |  |
| <b>Power Measurement Range</b>   | 0.1 W to 10 kW   |

|   |   |
|---|---|
| <b>Power Measurement Uncertainty</b>                                    | $\pm 5\%$ of full scale average power (95% c.l.)                                    |
| <b>Peak Power Measurement, 43 Elements only, Forward direction only</b> |   |
| <b>Pulse Width, Min</b><br>2 – 25 MHz<br>25 – 100 MHz<br>> 100 MHz      | 15 $\mu$ s<br>1.5 $\mu$ s<br>800 ns   |
| <b>Rep. Rate, Min</b>   | 15 pps  |
| <b>Duty Cycle, Min</b>  | $1 \times 10^{-4}$  |
| <b>Uncertainty<sup>b</sup></b>  | $\pm 8\%$ of full-scale peak envelope power (95% c.l.)                              |
| <b>Match Measurement</b>  |   |
| <b>Match Range</b><br>Return Loss<br>Rho ( $\rho$ )<br>VSWR             | 0 to 20 dB<br>0.1 to 1<br>1.22 to 99.99   |
| <b>Uncertainty</b>  | Twice the Avg Power Uncertainty (Calculated from forward and reflected uncertainty) |
| <b>Settling Time, Max</b>   | 2.5 seconds   |
| <b>Impedance, Nominal</b>   | 50 ohms   |
| <b>Insertion Loss, Max</b>  | 0.05 dB up to 1 GHz   |
| <b>Input VSWR, Max.</b>   | 1.05:1 up to 1 GHz  |
| <b>Directivity, Typical<sup>a</sup></b>                                 | 30 dB   |
| <b>RF Connectors</b>  | QC Type (N(F) normally supplied)  |
| <b>Power Supply</b>   | From host instrument via cable  |

|   |  |
|---|--|
| <b>Mechanical Shock and Vibration</b>   | In accordance with MIL-PRF-28800F Class 3          |
| <b>CE</b>                               | CE compliant. Refer to DOC for specific standards. |
| <b>Recommended Calibration Interval</b> | 1 year   |
| <b>Temp, Operating</b>                  | -10 to +50 °C (+14 to +122 °F)                     |
| <b>Temp, Storage</b>                    | -40 to +75 °C (-40 to +167 °F)                     |
| <b>Humidity, Max</b>                    | 95% (non-condensing)                               |
| <b>Altitude, Max</b>                    | 3,000 m (10,000 ft.)                               |
| <b>Dimensions, Nominal</b>              | 5.0" x 2.4" x 2.0"<br>(130 x 60 x 50 mm)           |
| <b>Weight, Nominal</b>                  | 0.9 lb. (0.4 kg)                                   |

- a. Exact value depends on element selected
- b. Above 35 °C or below 15 °C add 2%

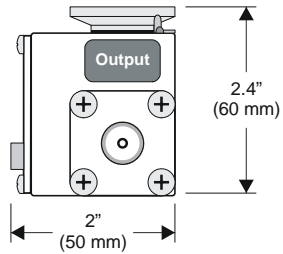
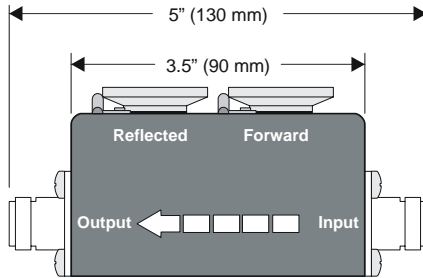
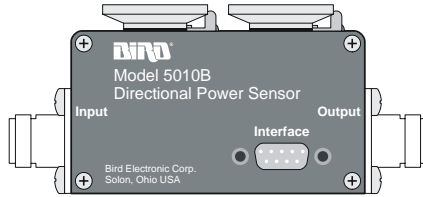

## 5014 Specifications

|  |  |
|--|--|
| <b>Sensor Type</b>   | Thru-line two-element line section   |
| <b>Elements</b>  | APM or 43 series elements. Select two elements from the same series, with RFL power 1/10 of FWD power. |
| <b>Frequency Range<sup>a</sup></b>   | 2 – 3600 MHz   |
| <b>Average Power Measurement, APM Elements, Forward or Reflected Direction</b> |  |
| <b>Power Measurement Range<sup>a</sup></b>                                     | 0.1 W to 1 kW  |
| <b>Uncertainty<sup>b</sup></b>   | ± 5% of reading (95% c.l.)   |
| <b>Peak/Average Ratio, Max</b>   | 10 dB  |
| <b>Average Power Measurement, 43 Elements, Forward or Reflected Direction</b>  |  |
| <b>Power Measurement Range</b>   | 0.1 W to 10 kW   |
| <b>Power Measurement Uncertainty</b>   | ± 5% of full scale average power (95% c.l.)  |
| <b>Peak Power Measurement, 43 Elements only, Forward direction only</b>        |  |
| <b>Pulse Width, Min</b><br>2 – 25 MHz<br>25 – 100 MHz<br>> 100 MHz             | 15 μs<br>1.5 μs<br>800 ns  |
| <b>Rep. Rate, Min</b>  | 15 pps   |
| <b>Duty Cycle, Min</b>   | $1 \times 10^{-4}$   |

|   |   |
|---|---|
| <b>Uncertainty<sup>b</sup></b>  | ± 8% of full-scale peak envelope power (95% c.l.)                                   |
| <b>Match Measurement</b>  |   |
| <b>Match Range</b><br><b>Return Loss</b><br><b>Rho (ρ)</b><br><b>VSWR</b> | 0 to 20 dB<br>0.1 to 1<br>1.22 to 99.99   |
| <b>Uncertainty</b>  | Twice the Avg Power Uncertainty (Calculated from forward and reflected uncertainty) |
| <b>Settling Time, Max</b>   | 2.5 seconds   |
| <b>Impedance, Nominal</b>   | 50 ohms   |
| <b>Insertion Loss, Max</b>  | 0.05 dB up to 1 GHz   |
| <b>Input VSWR, Max.</b>   | 1.05:1 up to 1 GHz  |
| <b>Directivity, Typical<sup>a</sup></b>                                   | 30 dB   |
| <b>RF Connectors</b>  | QC Type (N(F) normally supplied)  |
| <b>Power Supply</b>   | From host instrument via cable  |
| <b>Mechanical Shock and Vibration</b>                                     | In accordance with MIL-PRF-28800F Class 3   |
| <b>CE</b>   | CE compliant. Refer to DOC for specific standards.                                  |
| <b>Recommended Calibration Interval</b>                                   | 1 year  |

|                            |  |
|----------------------------|--|
| <b>Temp, Operating</b>     | -10 to +50 °C (+14 to +122 °F)           |
| <b>Temp, Storage</b>       | -40 to +75 °C (-40 to +167 °F)           |
| <b>Humidity, Max</b>       | 95% (non-condensing)                     |
| <b>Altitude, Max</b>       | 3,000 m (10,000 ft.)                     |
| <b>Dimensions, Nominal</b> | 5.0" x 2.4" x 2.0"<br>(130 x 60 x 50 mm) |
| <b>Weight, Nominal</b>     | 0.9 lb. (0.4 kg)                         |

- a. Exact value depends on element selected
- b. Above 35 °C or below 15 °C add 2%

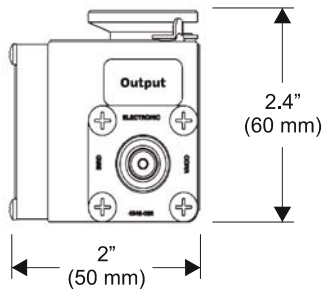
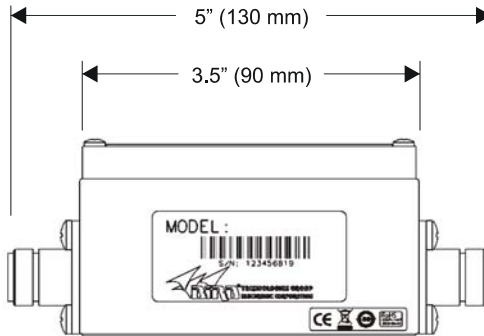
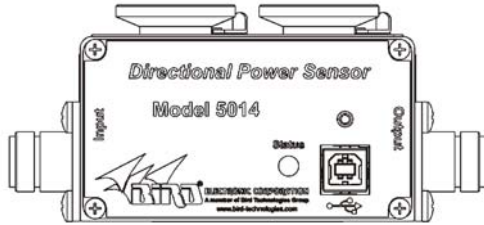

---

## Limited Warranty

All products manufactured by Seller are warranted to be free from defects in material and workmanship for a period of one (1) year, unless otherwise specified, from date of shipment and to conform to applicable specifications, drawings, blueprints and/or samples. Seller's sole obligation under these warranties shall be to issue credit, repair or replace any item or part thereof which is proved to be other than as warranted; no allowance shall be made for any labor charges of Buyer for replacement of parts, adjustment or repairs, or any other work, unless such charges are authorized in advance by Seller.

If Seller's products are claimed to be defective in material or workmanship or not to conform to specifications, drawings, blueprints and/or samples, Seller shall, upon prompt notice thereof, either examine the products where they are located or issue shipping instructions for return to Seller (transportation charges prepaid by Buyer). In the event any of our products are proved to be other than as warranted, transportation costs (cheapest way) to and from Seller's plant, will be borne by Seller and reimbursement or credit will be made for amounts so expended by Buyer. Every such claim for breach of these warranties shall be deemed to be waived by Buyer unless made in writing within ten (10) days from the date of discovery of the defect.

The above warranties shall not extend to any products or parts thereof which have been subjected to any misuse or neglect, damaged by accident, rendered defective by reason of improper installation or by the performance of repairs or alterations outside of our plant, and shall not apply to any goods or parts thereof furnished by Buyer or acquired from others at Buyer's request and/or to Buyer's specifications. Routine (regularly required) calibration is not covered under this limited warranty. In addition, Seller's warranties do not extend to the failure of tubes, transistors, fuses and batteries, or to other equipment and parts manufactured by others except to the extent of the original manufacturer's warranty to Seller.

The obligations under the foregoing warranties are limited to the precise terms thereof. These warranties provide exclusive remedies, expressly in lieu of all other remedies including claims for special or consequential damages. SELLER NEITHER MAKES NOR ASSUMES ANY OTHER WARRANTY WHATSOEVER, WHETHER EXPRESS, STATUTORY, OR IMPLIED, INCLUDING WARRANTIES OF MERCHANTABILITY AND FITNESS, AND NO PERSON IS AUTHORIZED TO ASSUME FOR SELLER ANY OBLIGATION OR LIABILITY NOT STRICTLY IN ACCORDANCE WITH THE FOREGOING.