INSTRUCTION BOOK

**TERMALINE[®] LOAD RESISTOR
SERIES 8890**



Bird[®] Electronic Corporation
30303 Aurora Road
Cleveland (Solon), Ohio 44139

Sales & Technical Support: 440-248-1200
866-695-4569 toll free
Sales email: sales@bird-technologies.com
Technical Support email: atechapp@bird-technologies.com

©Copyright 2009 by Bird Electronic Corporation
Instruction Book Part Number 920-8890S Rev. C

Termaline[®] and Tenuline[®] are Registered Trademarks
of Bird Electronic Corporation

Safety Precautions

The following are general safety precautions that are not necessarily related to any specific part or procedure, and do not necessarily appear elsewhere in this publication. These precautions must be thoroughly understood and apply to all phases of operation and maintenance.

WARNING

Keep Away From Live Circuits

Operating Personnel must at all times observe general safety precautions. Do not replace components or make adjustments to the inside of the test equipment with the high voltage supply turned on. To avoid casualties, always remove power.

WARNING

Shock Hazard

Do not attempt to remove the RF transmission line while RF power is present.

WARNING

Do Not Service Or Adjust Alone

Under no circumstances should any person reach into an enclosure for the purpose of service or adjustment of equipment except in the presence of someone who is capable of rendering aid.

WARNING

Safety Earth Ground

An uninterruptible earth safety ground must be supplied from the main power source to test instruments. Grounding one conductor of a two conductor power cable is not sufficient protection. Serious injury or death can occur if this grounding is not properly supplied.

WARNING

Resuscitation

Personnel working with or near high voltages should be familiar with modern methods of resuscitation.

WARNING

Remove Power

Observe general safety precautions. Do not open the instrument with the power on.

Safety Symbols

WARNING

Warning notes call attention to a procedure, which if not correctly performed, could result in personal injury.

CAUTION

Caution notes call attention to a procedure, which if not correctly performed, could result in damage to the instrument.

 **Note:** *Calls attention to supplemental information.*



This symbol indicates that a shock hazard exists if the precautions in the instruction manual are not followed.



The caution symbol appears on the equipment indicating there is important information in the instruction manual regarding that particular area. See page 17 for specific cautions.



This symbol indicates that the unit radiates heat and should not be touched while hot.



This symbol appears on the equipment and indicates the requirement for separate collection of discarded electrical and electronic equipment in accordance with the European Union Directive 2002/96/EC. Refer to the Bird web site (See “The Bird Web Site” on page 22) for more information.

Warning Statements

The following safety warnings appear in the text where there is danger to operating and maintenance personnel, and are repeated here for emphasis.

WARNING

The vent plug must be used at all times when the unit is operating or cooling. Failure to do so could result in an explosion or severe burns.

On page 5 and 6.

WARNING

Never attempt to connect or disconnect RF equipment from the transmission line while RF power is being applied. Leaking RF energy is a potential health hazard.

On page 7, 11, 13, 15 and 17.

WARNING

Turn off AC power and RF power when attaching the power cable.

On page 9.

WARNING

Disconnect the blower assembly from supply voltage before performing any maintenance.

On page 15

WARNING

Disconnect the unit from all power sources before servicing. The unit may be energized from multiple sources. The potential for electric shock exists.

On page 16, 17, 18 and 19.

WARNING

Do not operate with side panel removed. Doing so could result in personal injury.

On page 16.

Caution Statements

The following equipment cautions appear in the text and are repeated here for emphasis.

CAUTION

This load is designed for operation in a horizontal position only, with the vent plug up. Do not use in any other manner.

On page 5.

CAUTION

Do not contaminate the coolant with pipe sealant.

On page 6.

CAUTION

If installed, connect optional interlock before applying RF power.

On page 6.

CAUTION

Check the local electrical code for proper AC hookup prior to operation of the unit. Make sure the neutral or return hookup is only used for that purpose.

On page 9.

CAUTION

Make sure the interlock is properly connected when overloaded to prevent damage to the load.

On page 11.

CAUTION

Maximum power is 1,250 W when the blower is not running. If the indicator light should turn off, immediately reduce RF power to less than 1,250 W.

On page 13.

CAUTION

Use only Bird coolant, P/N 5-1070, to prevent damage to the load.

On page 17.

Safety Statements

USAGE

ANY USE OF THIS INSTRUMENT IN A MANNER NOT SPECIFIED BY THE MANUFACTURER MAY IMPAIR THE INSTRUMENT'S SAFETY PROTECTION.

USO

EL USO DE ESTE INSTRUMENTO DE MANERA NO ESPECIFICADA POR EL FABRICANTE, PUEDE ANULAR LA PROTECCIÓN DE SEGURIDAD DEL INSTRUMENTO.

BENUTZUNG

WIRD DAS GERÄT AUF ANDERE WEISE VERWENDET ALS VOM HERSTELLER BESCHRIEBEN, KANN DIE GERÄTESICHERHEIT BEEINTRÄCHTIGT WERDEN.

UTILISATION

TOUTE UTILISATION DE CET INSTRUMENT QUI N'EST PAS EXPLICITEMENT PRÉVUE PAR LE FABRICANT PEUT ENDOMMAGER LE DISPOSITIF DE PROTECTION DE L'INSTRUMENT.

IMPIEGO

QUALORA QUESTO STRUMENTO VENISSE UTILIZZATO IN MODO DIVERSO DA COME SPECIFICATO DAL PRODUTTORE LA PROIZIONE DI SICUREZZA POTREBBE VENIRNE COMPROMESSA.

SERVICE

SERVICING INSTRUCTIONS ARE FOR USE BY SERVICE - TRAINED PERSONNEL ONLY. TO AVOID DANGEROUS ELECTRIC SHOCK, DO NOT PERFORM ANY SERVICING UNLESS QUALIFIED TO DO SO.

SERVICIO

LAS INSTRUCCIONES DE SERVICIO SON PARA USO EXCLUSIVO DEL PERSONAL DE SERVICIO CAPACITADO. PARA EVITAR EL PELIGRO DE DESCARGAS ELÉCTRICAS, NO REALICE NINGÚN SERVICIO A MENOS QUE ESTÉ CAPACITADO PARA HACERLO.

WARTUNG

ANWEISUNGEN FÜR DIE WARTUNG DES GERÄTES GELTEN NUR FÜR GESCHULTES FACHPERSONAL.

ZUR VERMEIDUNG GEFÄHRLICHE, ELEKTRISCHE SCHOCKS, SIND WARTUNGSARBEITEN AUSSCHLIEßLICH VON QUALIFIZIERTEM SERVICEPERSONAL DURCHZUFÜHREN.

ENTRETIEN

L'EMPLOI DES INSTRUCTIONS D'ENTRETIEN DOIT ÊTRE RÉSERVÉ AU PERSONNEL FORMÉ AUX OPÉRATIONS D'ENTRETIEN. POUR PRÉVENIR UN CHOC ÉLECTRIQUE DANGEREUX, NE PAS EFFECTUER D'ENTRETIEN SI L'ON N'A PAS ÉTÉ QUALIFIÉ POUR CE FAIRE.

ASSISTENZA TECNICA

LE ISTRUZIONI RELATIVE ALL'ASSISTENZA SONO PREVISTE ESCLUSIVAMENTE PER IL PERSONALE OPPORTUNAMENTE ADDESTRATO. PER EVITARE PERICOLOSE SCOSSE ELETTRICHE NON EFFETTUARE ALCUNA RIPARAZIONE A MENO CHE QUALIFICATI A FARLA.

CONNECT INTERLOCK TO TRANSMITTER BEFORE OPERATING.

BRANCHER LE VERROUILLAGE À L'ÉMETTEUR AVANT EMPLOI.

CONECTE EL INTERBLOQUEO AL TRANSMISOR ANTES DE LA OPERACION.

VOR INBETRIEBNAHME VERRIEGELUNG AM SENDER ANSCHLIESSEN.

**PRIMA DI METTERE IN FUNZIONE L'APPARECCHIO, COLLEGARE IL
DISPOSITIVO DI BLOCCO AL TRASMETTITORE.**

About This Manual

This manual covers the operating and maintenance instructions for the following models

Note: When used in the rest of the manual, 889x refers to all models. 889x-300 refers only to loads without a blower. -315 and -320 refer to loads with attached blowers.

Connector	Model Number		
	Without Blower	Blower, 115 Vac	Blower, 230 Vac
Female LC	8890-300	8890-315	8890-320
3-1/8" EIA Flanged	8891-300	8891-315	8891-320
1-5/8" EIA Flanged	8892-300	8892-315	8892-320
1-5/8" EIA Unflanged	8895-300	8895-315	8895-320
3-1/8" Unflanged, Flush Center, 51.5Ω	8896-300		
3-1/8" Unflanged, Flush Center	8897-300	8897-315	8897-320
3-1/8" Unflanged, Recessed Center	8898-300	8898-315	8898-320
Digital, 3-1/8" EIA Flanged	8891D300		
Digital, 1-5/8" EIA Flanged	8892D300		8892D320
Digital, Female 13-30	8892D13-30		

Changes to this Manual

We have made every effort to ensure this manual is accurate. If you discover any errors, or if you have suggestions for improving this manual, please send your comments to our Solon, Ohio factory. This manual may be periodically updated. When inquiring about updates to this manual refer to the part number and revision on the title page.

Literature Contents

This instruction book is arranged so that essential information on safety is in the front of the book. Reading the Safety Precautions before operating the equipment is strongly advised. The remainder of this instruction book is divided into Chapters and Sections.

Chapter Layout

Introduction - Describes the features of the Bird SignalHawk, lists equipment supplied and optional equipment, and provides power-up instructions.

Theory of Operation - Describes how to use the SignalHawk's PC Tool for the Vector Network Analysis function and how to transfer readings from the SignalHawk to the computer and back again.

Operation without Blower - Describes procedures require for operating the load resistor.

Operation with Blower - Describes procedures require for operating the load resistor equipped with a blower unit.

Maintenance — Lists routine maintenance tasks as well as troubleshooting for common problems. Specifications and parts information are also included.

Table of Contents

Safety Precautions	i
Safety Symbols	i
Warning Statements	ii
Caution Statements	iii
Safety Statements	iv
About This Manual	vii
Changes to this Manual	vii
Literature Contents	vii
Chapter Layout	vii
Introduction	1
Items Supplied	1
Items Required but not Supplied	1
Optional Accessories	1
Chapter 1 Theory of Operation	3
Load Resistor	3
Coolant	3
Thermal Interlock	3
Blower Assembly	3
Chapter 2 Installation	5
Unpacking and Inspection	5
Setting Up	5
Mounting	5
Installing the Thermoswitch	6
Installing the Interlock Connection	6
Connecting RF Power	7
Using a “QC” Connector Coupling	7
Using a 13-30 Coupling	7
Using a Swivel Flanged Coupling	8
Using a Unflanged Coupling	8
Using an AC Power Hookup	9
Chapter 3 Operating Instructions, No Blower	11
Normal Operation	11
Operating Under Abnormal Conditions	11
Shutting Down	11
Emergency Shutdown	11
Chapter 4 Operating Instructions, With Blower	13
Blower Controls	13
Normal Operation	13
Operating Under Abnormal Conditions	13
Shutting Down	13
Emergency Shutdown	13

Chapter 5 Maintenance	15
Troubleshooting	15
Maintenance	16
Cleaning	16
Cleaning the Load Resistor	16
Cleaning the Blower Assembly	16
Inspecting	16
Inspecting the DC Resistance	16
Inspecting the Coolant Level	17
Repairing	18
Replacing the RF Connector	18
Replacing the Fuse	18
Replacing the Indicator Light	18
Replacing the Load Resistor	19
Replacing the Fan	19
Storage and Shipment	20
Storing the Load Resistor	20
Shipping the Load Resistor	20
Customer Service	21
Replacement Parts	23
Available “QC” Type Connectors	24
Limited Warranty	25

Bird 889x loads are portable, 50 ohm, coaxial RF transmission line terminations, designed for frequency ranges of DC – 2.4 GHz. 889xD loads are designed for use in the UHF (470 – 860 MHz) band but are otherwise identical. They provide accurate, dependable, and low reflection line terminations. Up to 2500 watts of RF power can be dissipated, 5000 watts if the optional blower assembly is used.

The –300 is the basic load. The –315 and –320 consist of a load with an installed blower assembly for 115 or 230 Vac lines, respectively.

The load has a coolant chamber surrounded by radiator fins. The front and rear fins form mounting flanges which can be used as supports for freestanding use or as brackets for fixed mounting. A vent plug at the top of the unit relieves internal pressure from coolant expansion. The load's simple and rugged design minimizes maintenance requirements.

Items Supplied

- Load Resistor: Pre-filled with coolant at the factory
- Shipping Plug
- Vent Plug
- Instruction Manual

Items Required but not Supplied

- **Coupling Kit:** Connects the load to the RF line

Optional Accessories

- **Bird BA-310 Blower Assembly:** Doubles the RF power capacity of the load. Includes control thermoswitch and detachable 3-wire power cable (without male plug for 230 Vac cable)
 - ☞ *The blower and control thermoswitch are standard on the –315 and –320 loads.*
- **Interlock Thermoswitch:** Automatically shuts off the transmitter to prevent overheating of the load.

Figure 1 Bird 8890 Series Outline Drawing - No Blower

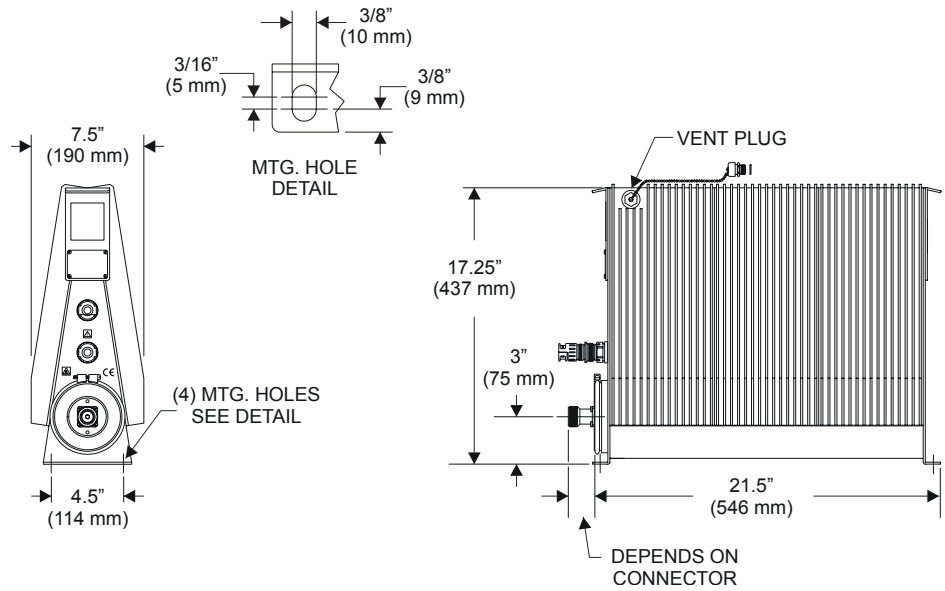
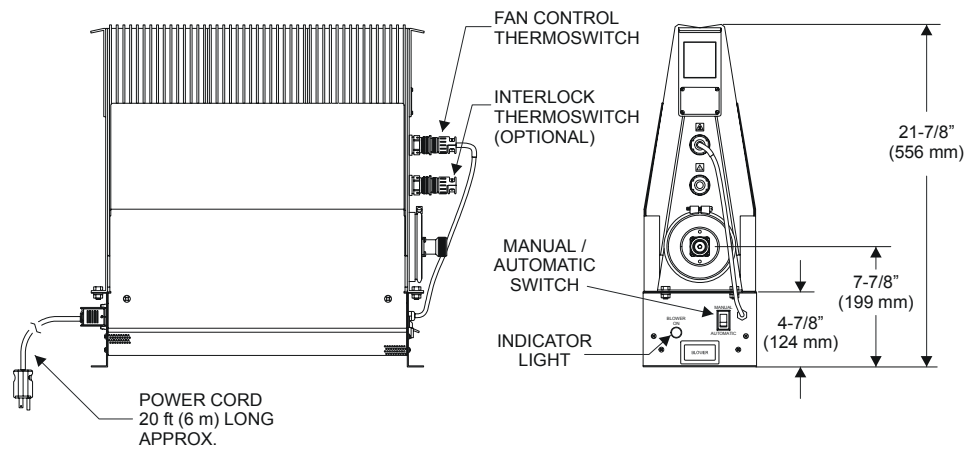

Figure 2 Outline Drawing With Blower



Load Resistor

Bird 889x loads consist of a thin-film-on-ceramic resistor immersed in a dielectric coolant. The resistor, individually selected for its accuracy, is enclosed in a special housing. When surrounded by the coolant, this produces a uniform, practically reflectionless line termination over the specified frequencies.

Coolant

The load is cooled by natural fluid and air convection currents. The coolant, chosen for its dielectric and thermal characteristics, carries heat from the resistor to the walls of the cooling tank, where radiator fins surrounding the tank transfer the heat to the air.

When the coolant is heated, thermal expansion causes an increase in the internal pressure. The vent plug (Figure 3, Detail "B") relieves this pressure while protecting the opening from dirt or other contaminants.

Thermal Interlock

When installed, a passive, normally closed over-temperature thermoswitch opens above the maximum safe load temperature of 236 °C (457 °F), turning off transmitter power. The interlock will not permit use of the transmitter until the load has reached a safe temperature.

Blower Assembly

When installed, the blower assembly provides forced airflow with two blowers. Baffles direct the airflow from the blowers over the radiator fins, doubling the heat transfer efficiency.

Example - A 2.5 kW load will safely dissipate 5 kW. A passive, normally open control thermoswitch closes when the coolant reaches 155 °C (311 °F), turning the fans on.

The baffles interfere with the free flow of normal air currents, causing a 50% reduction in heat transfer efficiency if the forced airflow is stopped. Thus, a 2.5 kW load will have its maximum power dissipation reduced to 1.25 kW.

Figure 3 Blower Plugs

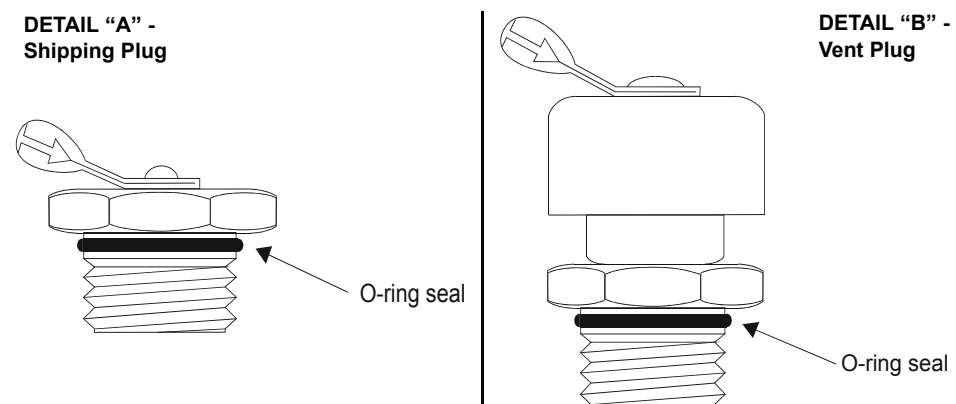

This chapter provides information for on-site requirements, unpacking, inspection, and preparing the load for use.

Unpacking and Inspection

1. Carefully inspect shipping container for signs of damage.
2. Do one of the following:
 - If the shipping container is damaged, do not unpack the unit. Immediately notify the shipping carrier and Bird Electronic Corporation.
 - If the shipping container is not damaged, unpack the unit. Save shipping materials for repackaging.
3. Inspect unit for visual signs of damage.

 **Note:** *If there is damage, immediately notify the shipping carrier and Bird Electronic Corporation.*

Setting Up

- Before first using the load, get a resistance baseline for future maintenance. Refer to "Inspecting the DC Resistance" on page 16 for details.
- Remove the shipping plug from the load and replace it with the vent plug. Refer to Figure 3 for pictures of the plugs.

WARNING

The vent plug must be used at all times when the unit is operating or cooling. Failure to do so could result in an explosion or severe burns.

Mounting

Place the load in a dry, dust and vibration free environment. Do not use outdoors or in areas of condensing humidity. Allow at least 12" (30 cm) of clearance on all sides of the load.

CAUTION

This load is designed for operation in a horizontal position only, with the vent plug up. Do not use in any other manner.

Bird 889x Loads are equipped for either portable use or fixed installation. The mounting brackets on the front and rear faces have four mounting slots arranged in a $4\frac{1}{2}$ " x $20\frac{23}{32}$ " rectangle (114.3 x 526.3 mm). Use a screw with a $\frac{3}{8}$ " (9.53 mm) diameter max.

Installing the Thermoswitch

Bird 889x series Loads can be equipped with an optional interlock thermoswitch, P/N 8890-008. It is normally closed, opening at 236 °C (457 °F), with a rating of 10A @ 120Vac and 5A @ 230Vac.

Note: A control thermoswitch, P/N 2450-085, is used to control the optional blower assembly. It is normally open, closing at 155 °C (311 °F), with a rating of 10A @ 120Vac and 5A @ 230Vac.

WARNING

The vent plug must be used at all times when the unit is operating or cooling. Failure to do so could result in an explosion or severe burns.

1. Remove the vent plug.
2. Install the shipping plug.
3. Stand the unit on its back with the connector end up.

Note: In this position there is no danger of the coolant pouring out through the socket plug hole.
4. Do one of the following:
 - **For Interlock Thermoswitch:**
Remove the socket plug just above the connector assembly with a $\frac{9}{16}$ " hex wrench. See "Installing the Interlock Connection" on page 6.
 - **For Control Thermoswitch:**
Remove the top socket plug with a $\frac{9}{16}$ " hex wrench.
5. Replace the plug with the thermoswitch.
6. Apply pipe sealing compound to the external threads of the thermoswitch sparingly, ONLY.

CAUTION

Do not contaminate the coolant with pipe sealant.

7. Check for coolant leaks upon completion.

Installing the Interlock Connection

CAUTION

If installed, connect optional interlock before applying RF power.

1. Unscrew the large knurled ring-nut (A) at the lower end of the coupling jack assembly.
2. Pull the large knurled nut off the thermoswitch jack (B).
3. Unscrew the small knurled cover fitting from the base plug (D) of the connector to release the base.
4. Thread the control switch wires through the clamp (E) with the washers (F) inside and with its threaded fitting in place.
5. Service the control switch wire with short tips and put spaghetti sleeves over the wire ends if necessary.

6. Securely solder the control switch leads to the lugs (G) of the connector base.
 -  **Note:** The ring-nut (A) must be in place over the base plug (D) with the knurled end facing out.
7. Screw on the cover ring, then fasten the cable clamp (E) in place and tighten both yoke screws (H).
8. Put the plug back on the thermoswitch and tighten the nut (A).

Figure 4 Thermoswitch Assembly



Connecting RF Power

After installing the load, the RF transmission line can be attached using standard coaxial line coupling kits.

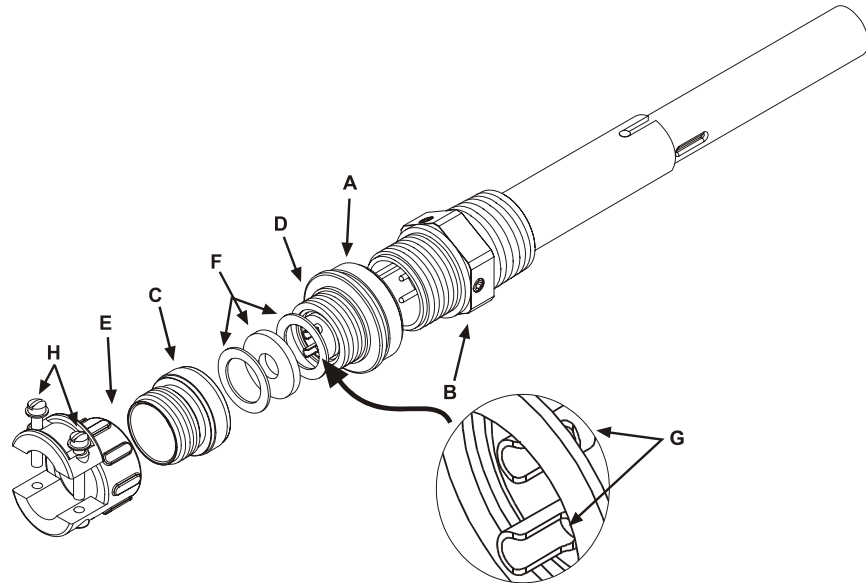
WARNING

Never attempt to connect or disconnect RF equipment from the transmission line while RF power is being applied. Leaking RF energy is a potential health hazard.

Using a “QC” Connector Coupling

Use 50 ohm coaxial cable such as RG-218/U or -220/U (-17A or -19A), appropriate for the frequency and power level of operation. Use a cable connector which will mate with the one on the load.

Using a 13-30 Coupling

Use 50 ohm coaxial cable such as RG-8A/U, RG-9U, RG-213/U, or equivalent with a male 13-30 plug.

Using a Swivel Flanged Coupling

To couple the swivel flange with a flanged RF transmission line, use an appropriate coupling kit. Refer to Figure 5 while following the instructions.

Figure 5 Swivel Flanged Coupling

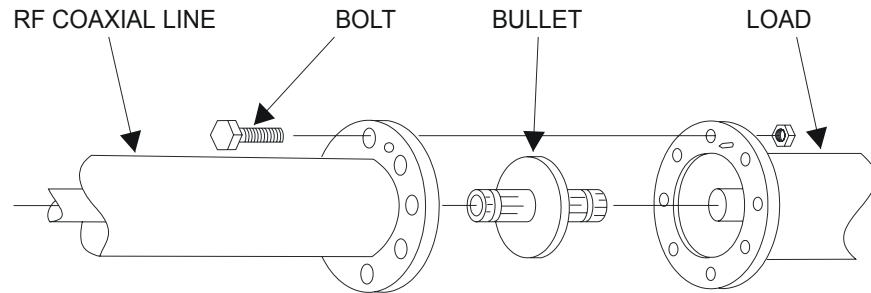

1. Insert the center bullet.
2. Push it in until it is fully seated.
3. Connect the coaxial input in a straight line
4. Push carefully on the center conductor to close.

Note: *The swivel flange on the load makes connection independent of the orientation of the fixed flange on the coaxial input outer conductor.*

5. Insert the bolt sets and tighten evenly all around to transmission line manufacturer's recommended torque.

Note: *Use all of the bolts.*

Using an Unflanged Coupling

To couple the unflanged connector with an unflanged RF line, use an appropriate coupling kit. Refer to Figure 7 while following the instructions.

Figure 6 Unflanged Coupling

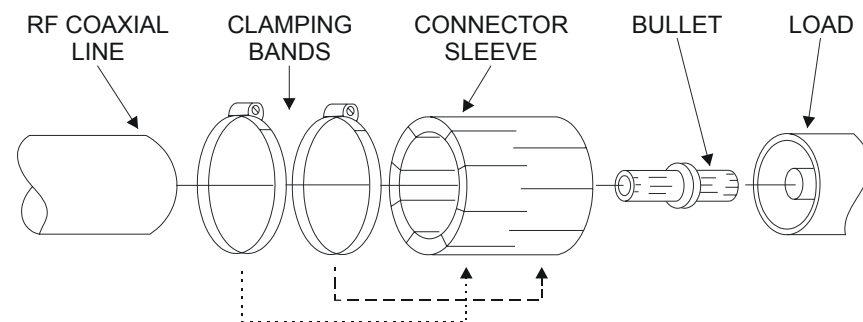

1. Insert the center bullet
2. Push until it sets the midpoint nibs.
3. Position the outer sleeve, with clamping bands, over the input connector.
4. Set the transmission line snugly against the coupling stops.
5. Position the clamping bands evenly about 3/4" from the ends of the sleeve.
6. Tighten the clamping bands.

Using an AC Power Hookup

WARNING

Turn off AC power and RF power when attaching the power cable.

CAUTION

Check the local electrical code for proper AC hookup prior to operation of the unit. Make sure the neutral or return hookup is only used for that purpose.

AC power is only required if the blower assembly is installed. The AC power supply required is 115/230 V, depending on the blower, @ 50/60 Hz, 1 ϕ . The blower is equipped with an IEC 320 “cold” (65 °C) AC inlet.

Normal Operation

Bird 889x–300 loads have no indicators or operating controls. They require no special operating procedures or surveillance when their performance limits are not exceeded. Follow the instructions for the specific transmitter equipment.

Operating Under Abnormal Conditions

The load can be subjected to moderate overloads for short periods.

CAUTION

Make sure the interlock is properly connected when overloaded to prevent damage to the load.

Shutting Down

These loads are passive devices, so have no way of being turned off. Turn off RF power at the source.

WARNING

Never attempt to connect or disconnect RF equipment from the transmission line while RF power is being applied. Leaking RF energy is a potential health hazard.

Emergency Shutdown

Turn off RF power at the source.

Note: *If the interlock thermoswitch is properly connected, RF power will be automatically turned off when the coolant temperature reaches an unsafe level.*

CAUTION

Maximum power is 1,250 W when the blower is not running. If the indicator light should turn off, immediately reduce RF power to less than 1,250 W.

WARNING

Never attempt to connect or disconnect RF equipment from the transmission line while RF power is being applied. Leaking RF energy is a potential health hazard.

Blower Controls

Bird 889x-310 and -320 Loads are equipped with a control switch and indicator light on the front of the blower assembly. The switch is labelled MANUAL/AUTOMATIC.

- When the switch is set to MANUAL, the fans will run continuously.
- When set to AUTOMATIC, the fans will be turned on when the coolant reaches a preset temperature.

The indicator light, labeled BLOWER ON, will turn on whenever the unit is connected to AC power.

Normal Operation

1. Check that the indicator light is on.
2. Set the switch to MANUAL momentarily.
3. Check that the fans are working properly.
4. Set the switch back to AUTOMATIC.
5. Apply RF power.

Operating Under Abnormal Conditions

If the indicator light turns off or the fans stop unexpectedly, immediately turn off RF power or reduce it to less than 1,250 W. Refer to "Troubleshooting" on page 15 to correct the problem. A properly connected interlock will prevent overload.

The load can be subjected to higher power levels for short intervals. If this is likely, make sure the interlock is properly connected to prevent damage to the load.

Shutting Down

1. Turn off RF power at the source.
2. Wait approximately 15 minutes, or for the fans to stop running.
 - 🔧 **Note:** *This will allow the load to cool without causing heat stress.*
3. Turn off the blower.

Emergency Shutdown

Turn off RF power at the source.

🔧 **Note:** *If the interlock thermoswitch is properly connected, RF power will be automatically turned off when the coolant temperature reaches an unsafe level.*

This chapter covers cleaning, inspection, trouble-shooting, and specifications for the Bird 889x Loads.

WARNING

Never attempt to connect or disconnect RF equipment from the transmission line while RF power is being applied. Leaking RF energy is a potential health hazard.

WARNING

Disconnect the blower assembly from supply voltage before performing any maintenance.

Troubleshooting

The table below contains troubleshooting information for problems which can occur during normal operation. This manual cannot list all malfunctions that may occur, or their corrective actions. If a problem is not listed or is not corrected by the listed actions, notify a qualified service center.

PROBLEM	POSSIBLE CAUSE	CORRECTION
No air flow from blowers; "BLOWER ON" light off	Unplugged power cable	Connect the power cable.
	No AC power	Make sure AC power is properly connected and turned on.
	Fuse burnout	Replace fuse after correcting the burnout cause (See "Replacing the Fuse" on page 18).
No air flow from blowers; "BLOWER ON" light on	Fan obstructed by bent grill	Straighten the grill.
	Fan motors overheated	Clean the grill and fan blades (See "Cleaning the Load Resistor" on page 16).
	Fan motors burnt out	Replace the fan motors (See "Replacing the Fan" on page 19).
Air flow from blowers; "BLOWER ON" light off	Lamp burnout	Replace lamp (See "Replacing the Indicator Light" on page 18).
Leaking coolant	Loose clamping band	Tighten the clamping band.
	Defective or improperly installed O-ring	Replace the O-ring (See "Replacing the Load Resistor" on page 19).
High or low DC resistance	Loose RF input connector	Tighten connector.
	Faulty RF input connector	Model 8890: Replace connector (See "Replacing the RF Connector" on page 18).
		All other models: Return the unit for service.
Faulty resistor	Replace the resistor (See "Replacing the Load Resistor" on page 19).	
Overheating radiator	RF power too high	Lower RF power (See "Specifications" on page 22 for maximum RF power).
	Coolant level too low	Check the coolant level. Add coolant if necessary (See "Inspecting the Coolant Level" on page 17).
	Coolant degraded	Replace the coolant (See "Inspecting the Coolant Level" on page 17).
	Faulty control thermoswitch (blower only)	Replace control thermoswitch (See "Installing the Thermoswitch" on page 6).
	Faulty resistor	Replace the resistor (See "Replacing the Load Resistor" on page 19).

Maintenance

Cleaning

Cleaning the Load Resistor

- The outside surface of the instrument should be wiped free of dust and dirt when necessary.
- Excessive dust on the cooling fins will interfere with heat dissipation.
- Clean the RF connector, both metallic and insulating surfaces, with a dry, non-residue forming solvent.

Cleaning the Blower Assembly

The intake grills, fans, and inside of the baffles should be wiped free of dust and dirt when necessary. Excessive dust will interfere with heat dissipation. When the blower assembly is installed, it will be necessary to partially disassemble the blower to clean the load's radiator fins.

WARNING

Disconnect the unit from all power sources before servicing. The unit may be energized from multiple sources. The potential for electric shock exists.



WARNING

Do not operate with side panel removed. Doing so could result in personal injury.

1. Remove one of the side baffles by unscrewing both 10-32 truss head screws.
2. Clean the load
3. Screw the baffle back into place.

Inspecting

- Inspect the unit every six months.
- Check for coolant leakage around the clamping band.
- Check for coolant leakage around the thermoswitch.
- Check for corrosion.

Inspecting the DC Resistance

Measuring the DC resistance between the inner and outer conductors of the RF connector shows changes in the load over time, a good check of the load resistor's condition. Under normal operating conditions, the resistor should provide at least 5,000 hours of operation before requiring any additional service. DC resistance tracking must start before the load is put into service, and should be measured annually.

Perform this procedure record the value for future comparison.

Note: Use an ohmmeter with an accuracy of $\pm 1\%$ at 50 ohms and that the load temperature is between 20 and 25 °C (68 to 77 °F).

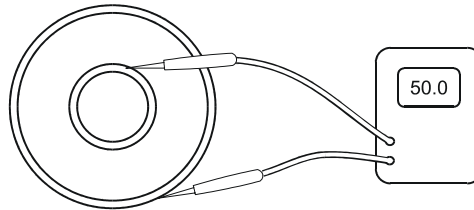
Figure 7 Measuring Resistance**WARNING**

Never attempt to connect or disconnect RF equipment from the transmission line while RF power is being applied. Leaking RF energy is a potential health hazard.

1. Turn off the RF power and interlock circuitry.
2. Disconnect the RF line.
3. Connect the multimeter test leads to the center and outer conductor of the load resistor. Refer to Figure 7.
4. Compare the measured value with the previous measurement and with the baseline resistance, measured when the load was put into service.

Note: *If the new value differs from either of these by more than 2 ohms this could indicate a failing resistor.*

Inspecting the Coolant Level

Coolant lifetime will vary greatly depending on the operating temperature.

- **Heavy Use (full RF power for long times, high ambient temperature, 50 Hz AC supply):**
Inspect the coolant every 500 hours.
- **Light Use (fraction of full power, low ambient temperature, 60 Hz AC supply):**
Inspect coolant every 2,000 hours.

Note: *Correct any coolant leakage before inspection. (See "Troubleshooting" on page 11)*

WARNING

Disconnect the unit from all power sources before servicing. The unit may be energized from multiple sources. The potential for electric shock exists.

1. Remove the load resistor (Refer to "Load Resistor" on page 18).

CAUTION

Use only Bird coolant, P/N 5-1070, to prevent damage to the load.

2. Inspect the coolant.
 - The coolant should be clear, with a faint yellow tinge, and have a slightly sweet smell. If it is black with a burnt or acrid smell, drain it and add about 2.9 gal (11 L) of coolant.
 - With the load still on end, the coolant level should be 4³/₄ to 5 inches (125 mm) below the top surface of the resistor assembly mounting ring, at ambient temperature.
3. Add coolant if necessary.

Repairing

WARNING

Disconnect the unit from all power sources before servicing. The unit may be energized from multiple sources. The potential for electric shock exists.

Replacing the RF Connector

ONLY the Model 8890 has a special Bird “QC” connector which allows easy changing of the RF connector. This does not disturb the coolant seal or affect the electrical continuity of the load. To change the connector, proceed as follows:

1. Remove the four screws at the corners of the RF connector.
2. Pull the connector straight out.
3. Push the new connector in. Make sure that the center pin on the connector is properly seated in the mating socket on the load.
4. Replace the screws.

Note: *If not using the LC connector normally supplied, the frequency and power must be limited to the capabilities of the connector.*

Replacing the Fuse

WARNING

Disconnect the unit from all power sources before servicing. The unit may be energized from multiple sources. The potential for electric shock exists.

Note: *The fuse is located in the AC module on the back of the blower.*

1. Correct the fuse burnout cause.

Note: *Common causes include stuck or blocked fans or a short circuit in the motor or blower wiring.*
2. Press the locking tab on the fuse drawer and remove the drawer.
3. Replace the fuse.

Note: *See “Specifications” on page 22 for fuse type and current rating.*
4. Push the drawer into the AC module until it locks into place.

Note: *If the fans still do not run or if the fuse burns out again, return the blower assembly to the factory.*

Replacing the Indicator Light

1. Remove the four 8-32 pan head screws from the front and back of the base frame.
2. Pull the fan guard straight off the bottom.
3. Remove the quick disconnects on the light and unscrew the retaining sleeve.
4. Remove the light unit.
5. Remove the lens while pressing both locking tabs.
6. Press the housing’s center slot with a small screwdriver to release the lamp.
7. Push the new lamp into the housing until it snaps into place.
8. Replace the lens, then put the light unit back in place.
9. Replace the fan guard and screw in the 8-32 pan head screws.

Replacing the Load Resistor

1. Remove the vent plug and install the shipping plug.
2. Stand the unit on its back with the connector end up.
 - Note:** *In this position there is no danger of the coolant pouring out through the socket plug hole.*
3. Unscrew and remove the clamping band.
4. Lift the load resistor assembly out of the tank and allow any coolant to drip back into the tank.
5. Check the O-Ring.
 - Note:** *It should be free of twists and positioned evenly around the flange of the resistor housing.*
 - Note:** *If the O-ring shows signs of deterioration (e.g. is no longer pliable or has surface cracks) replace it.*
6. Replace the entire load resistor assembly.
 - Note:** *It cannot be further disassembled.*
7. Put the clamping band in place and tighten it.
8. Remove the shipping plug and install the vent plug.

Replacing the Fan

WARNING

Disconnect the unit from all power sources before servicing. The unit may be energized from multiple sources. The potential for electric shock exists.

1. Remove the four 8-32 pan head screws from the front and back of the base frame.
2. Pull the fan guard straight off the bottom.
3. Carefully unsolder the color coded connecting wires.
 - Note:** *Note the connections for resoldering.*
4. Remove the four fan mounting screws.
5. Remove the defective fan.
 - Note:** *Be careful not to lose the lipped retaining washers.*
6. Insert the replacement fan with the fan blade assembly facing down, towards the fan guard grill.
7. Insert the mounting screws and retaining washers into the mounting holes.
8. Turn the washers so that the lipped portion fits over the rim of the fan frame.
9. Tighten the screws.
 - Note:** *If the fan replaced is the one closest to the power socket, reattach the green ground wire to the closest mounting screw.*
10. Solder the connecting wires to the solder lugs on the motor unit according to the color coding.
11. Replace the fan guard and screws.
 - Note:** *Before reattaching the blower assembly to the load, check the fans for free and unimpeded movement of the blades.*
12. Connect the unit to AC power.
13. Set the switch to MANUAL momentarily to check that the fans work properly.
14. Set the switch back to AUTOMATIC.

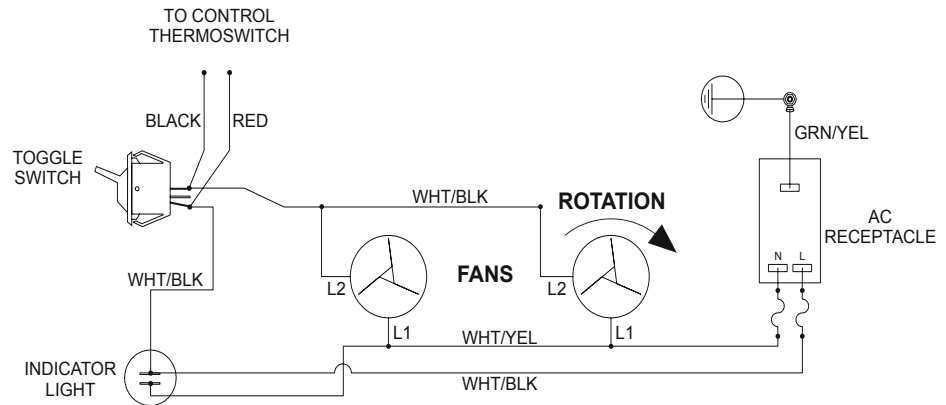
Figure 8 Schematic Diagram

Storage and Shipment

Storing the Load Resistor

- Cover Bird 8890 Loads before storing to keep out dust and dirt.
- It is not necessary to install the shipping plug.
- Store in a dry, dust-free environment where the ambient temperature will remain between -40 and $+45$ °C (-40 to $+113$ °F).

Shipping the Load Resistor

1. Remove the vent plug.
2. Install the shipping plug.
3. Wrap the vent plug with padding and tape it to the side of the load for protection.

Note: *With the shipping plug installed, it is not necessary to empty out the coolant.*

4. Wrap the connector in padding.
5. Pack and brace the load in a sturdy wooden crate for shipment.

Customer Service

Any maintenance or service procedure beyond the scope of those in this chapter should be referred to a qualified service center.

If you need to return the unit for any reason, request an RMA through the Bird Technologies website (link shown below). All instruments returned must be shipped prepaid and to the attention of the RMA number.

Bird Service Center

30303 Aurora Road
Cleveland (Solon), Ohio 44139-2794
Fax: (440) 248-5426
E-mail: bsc@bird-technologies.com

For the location of the Sales Office nearest you, visit our website at:

<http://www.bird-technologies.com>

Specifications

Frequency Range	
8891D300, 8892D300, 8892D13-30, 8892D320	470 – 860 MHz
All other models	DC – 2.4 GHz
Power Rating*	
	2500 W continuous duty
Peak Power for Pulse Width†	
1 μ s	150 kW
10 μ s	115 kW
100 μ s	80 kW
1000 μ s	54 kW
5000 μ s	22 kW
Impedance	
8896	51.5 ohms
All other models	50 ohms
VSWR	
8891D300, 8892D300, 8892D13-30, 8892D320	1.065
All other models	DC – 1 GHz 1.1 1 – 2 GHz 1.25 2 – 2.4 GHz 1.3
Connectors	
8890	Female LC
8891, 8891D300	3-1/8" EIA flanged
8892, 8892D300, 8892D320	1-5/8" EIA flanged
8892D13-30	Female 13-30
8895	1-5/8" EIA unflanged
8896	3-1/8" unflanged (flush center)
8897	3-1/8" unflanged (flush center)
8898	3-1/8" unflanged (recessed center)
AC Power	
-315	115 V \pm 10% @ 50/60 Hz \pm 3%
-320	230 V \pm 10% @ 50/60 Hz \pm 3%
AC Line Power Rating	
	460 W max
Fuse Rating	
	IEC (5 x 20 mm) Type T
115 Vac	1 A
230 Vac	500 mA
Thermoswitch	
Interlock	Normally closed. Opens at 236 °C (457 °F)
Fan Control	Normally open. Closes at 155 °C (311 °F)
Thermoswitch Rating	
115 Vac	10 A
230 Vac	5 A
Ambient Temperature	
	-40 to +45 °C (-40 to +113 °F)
Altitude‡	
	1520 m (5000 ft.)
Humidity	
	95% noncondensing max
Cooling method	
	Oil dielectric and convection currents
Dimensions	
Without blower	21.75" L x 7.5" W x 17.25" H (551 x 190 x 437 mm)
With blower	21.75" L x 7.5" W x 21 1/8" H (551 x 190 x 556 mm)
Weight, Nominal	
	59 lb. (27 kg)
Finish	
	Grey Powder Coat

* Power rating with blower installed and operating: 5000 W

Power rating with blower installed and *NOT* operating: 1250 W

† Set the duty factor so that the average power rating of the load is not exceeded.

‡ Derate RF power by 2.5% for every 305m (1,000 ft.) above 1,520m (5,000 ft.).

Replacement Parts

DESCRIPTION	QTY	PART NUMBER
RF load resistor	1	
8890		8890-050
8891		8891-050
8891D300		8891-071
8892, 8892D300		8892-015
8892D13-30		8862-017
8895		8896-015
8896		8896-031
8897		8897-003
8898		8898-006
Resistor O-Ring	1	5-230
Clamping band assembly	1	2430-055
Plug	1	
Vent		2450-094
Shipping		2450-049
Overtemp thermostat	1	8890-008
Thermostat body	1	8890-005
Thermostat jack	1	2450-018
Control thermostat*	1	2450-085
Thermostat body	1	2450-086
Thermostat jack	1	2450-018
Coolant, 2.9 gal (11 liters)	1	5-1070
Radiator assembly	1	2450-313
Access plug 3/4"-14 hex socket	1	5020-103
Blower assembly, BA-300†	1	
115 Vac		BA-300-115
230 Vac		BA-300-230
Blower assembly, BA-310*	1	
115 Vac		BA-310-115
230 Vac		BA-310-230

* Optional on the -300, standard on the -315 and -320

† Optional on the -300

Available “QC” Type Connectors

Connector	Part Number
BNC-Female	4240-125
BNC-Male	4240-132
C-Female	4240-100
C-Male	4240-110
HN-Female	4240-268
HN-Male	4240-278
LC-Female*	4240-031
LC-Male	4240-025
Open Term.# 10-32 Nut	4240-080
LT-Female	4240-018
LT-Male	4240-012
N-Female	4240-062
N-Male	4240-063
SC-Female	4240-090
SMA-Female	4240-336
SMA-Male	4240-334
7/16 Jack, IEC Type 169-4	4240-344
7/16 Plug, IEC Type 169-4	4240-363
Mini UHF-Female	4240-346
UHF-Female	4240-050
UHF-Male	4240-179
1-5/8" EIA Fixed	4240-096
1-5/8" EIA Swivel	4240-208
7/8" EIA	4240-002
TNC-Female	4240-156
TNC-Male	4240-160

* Normally supplied on the 8890

Limited Warranty

All products manufactured by Seller are warranted to be free from defects in material and workmanship for a period of one year, unless otherwise specified, from date of shipment and to conform to applicable specifications, drawings, blueprints and/or samples. Seller's sole obligation under these warranties shall be to issue credit, repair or replace any item or part thereof which is proved to be other than as warranted; no allowance shall be made for any labor charges of Buyer for replacement of parts, adjustment or repairs, or any other work, unless such charges are authorized in advance by Seller.

If Seller's products are claimed to be defective in material or workmanship or not to conform to specifications, drawings, blueprints and/or samples, Seller shall, upon prompt notice thereof, either examine the products where they are located or issue shipping instructions for return to Seller (transportation-charges prepaid by Buyer). In the event any of our products are proved to be other than as warranted, transportation costs (cheapest way) to and from Seller's plant, will be borne by Seller and reimbursement or credit will be made for amounts so expended by Buyer. Every such claim for breach of these warranties shall be deemed to be waived by Buyer unless made in writing within ten days from the date of discovery of the defect.

The above warranties shall not extend to any products or parts thereof which have been subjected to any misuse or neglect, damaged by accident, rendered defective by reason of improper installation or by the performance of repairs or alterations outside of our plant, and shall not apply to any goods or parts thereof furnished by Buyer or acquired from others at Buyer's request and/or to Buyer's specifications. Routine (regularly required) calibration is not covered under this limited warranty. In addition, Seller's warranties do not extend to the failure of tubes, transistors, fuses and batteries, or to other equipment and parts manufactured by others except to the extent of the original manufacturer's warranty to Seller.

The obligations under the foregoing warranties are limited to the precise terms thereof. These warranties provide exclusive remedies, expressly in lieu of all other remedies including claims for special or consequential damages. SELLER NEITHER MAKES NOR ASSUMES ANY OTHER WARRANTY WHAT-SOEVER, WHETHER EXPRESS, STATUTORY, OR IMPLIED, INCLUDING WARRANTIES OF MERCHANTABILITY AND FITNESS, AND NO PERSON IS AUTHORIZED TO ASSUME FOR SELLER ANY OBLIGATION OR LIABILITY NOT STRICTLY IN ACCORDANCE WITH THE FOREGOING.